



STENCIL SURFACE

Creative Surface Lighting System



Stencil Surface

Added simplicity through innovation

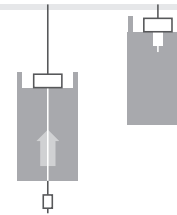

Stencil Surface makes a quiet statement on the ceiling plane that helps define the space, on and off the grid.

Its innovative patent-pending elements overcome many challenges associated with surface luminaires, allowing you to articulate lighting concepts in line with architectural layouts.

Discover new lighting opportunities with Stencil Surface.

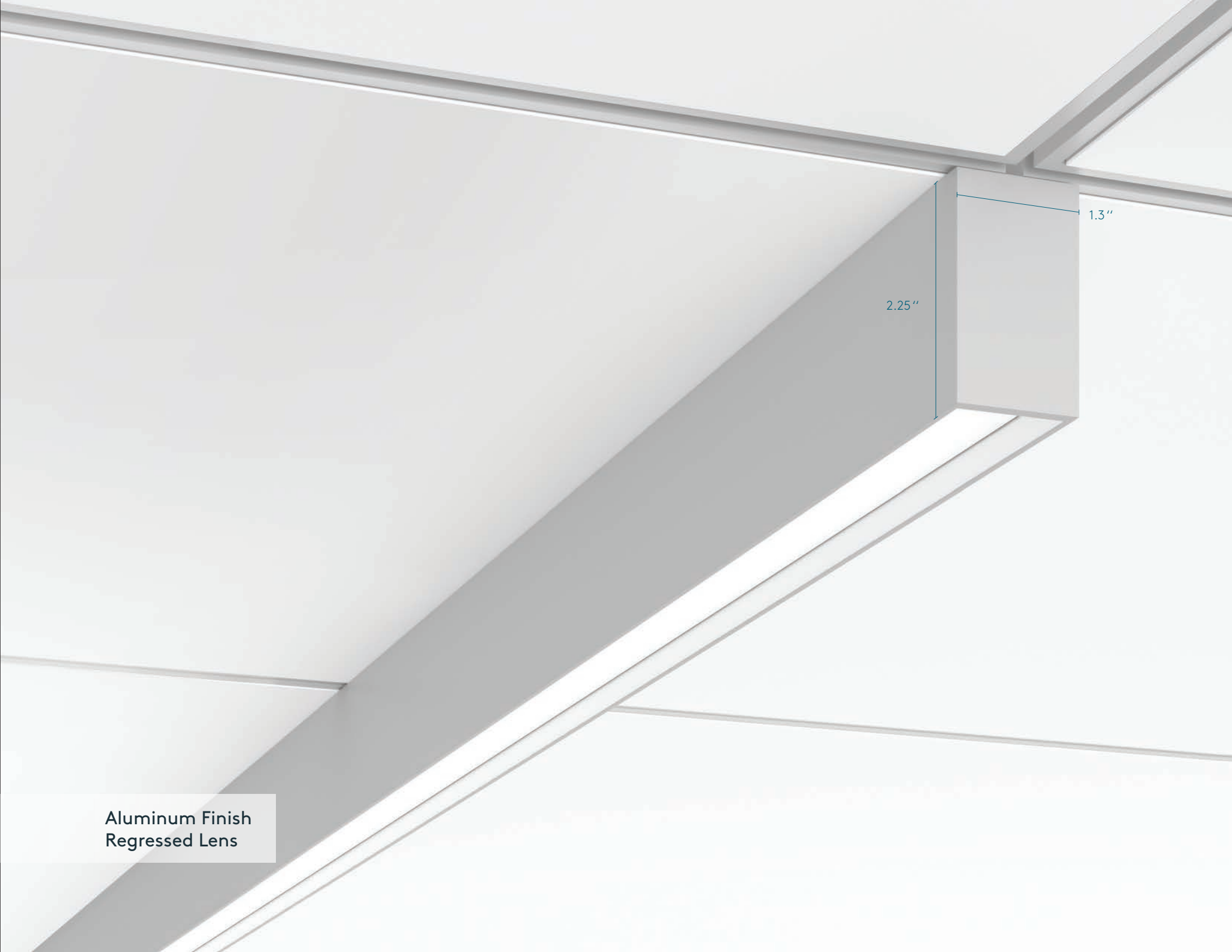

Aluminum Finish
Regressed Lens

Minimalist

A subtle footprint giving the space center stage

Fine-tune design coherence without drawing attention to the lighting. Embrace the grid with Stencil Surface, a slender form that conceals gridlines while blending into the ceiling. Stencil Surface features no visible hardware, further reducing the visual noise of the lighting system.



White Finish
Flush Lens

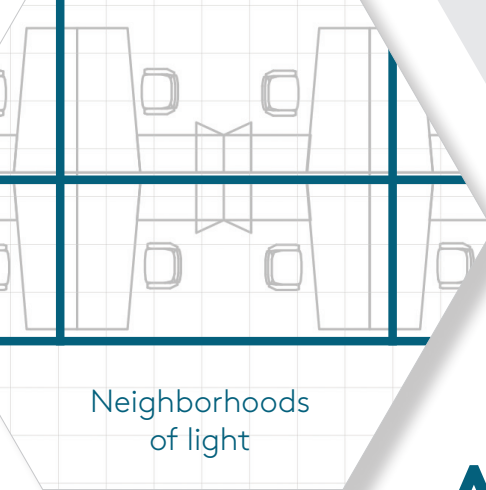

Neighborhoods
of light

Adaptive

Lighting design flexibility you can work with

Underscore design themes with discreet traces of light. Stencil Surface lends itself to the creation of streamlined shapes and patterns that support a room's purpose and multiple functions. Its clean look and extensive possibilities let you suggest rhythm, communicate meaning and create neighborhoods of light.

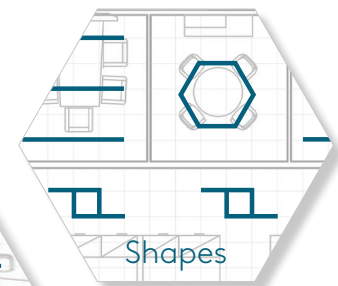
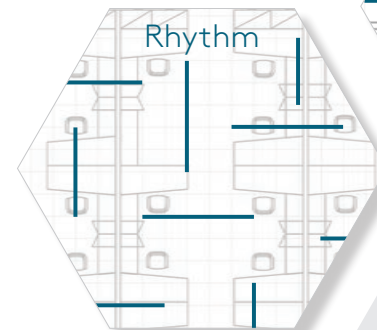

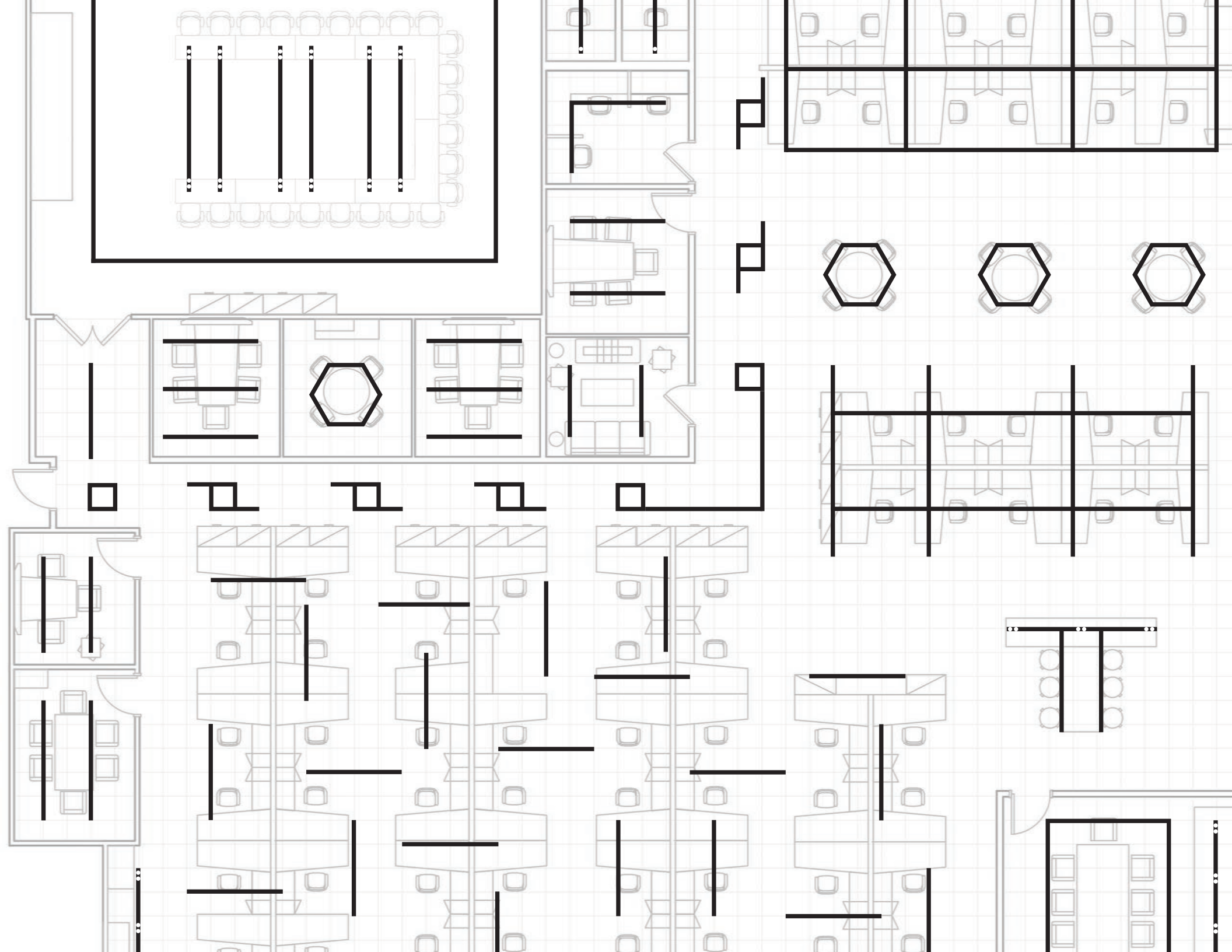

Integrated

A pure, seamless appearance

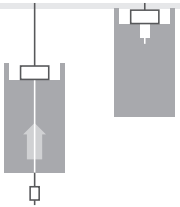

The innovative patent-pending surface attachment system with concealed hardware and power feed lets you put Stencil Surface anywhere, on and off the grid, including drywall and concrete ceilings. It results in quick and easy design and installation, shorter project timelines and significant cost reductions.



Black Finish
Flush Lens

Innovative Mounting

A faster, more flexible approach

- ✓ Total installation freedom: Place Stencil Surface anywhere
- ✓ Added installation convenience – On and off the grid
- ✓ Fast installation process: Hassle-free and more affordable



Patent-pending seamless grid installation and power feed system

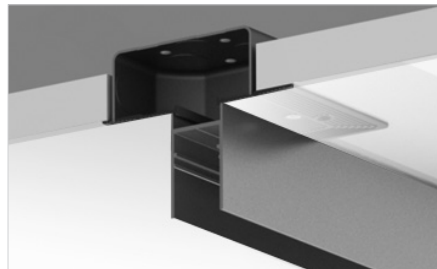

Patent-pending concealed drywall spackle power/control module combines power, control and wire feeds.



An integral 0-10V dimmable LED mini-driver provides up to 200' of continuous light from a single power feed.

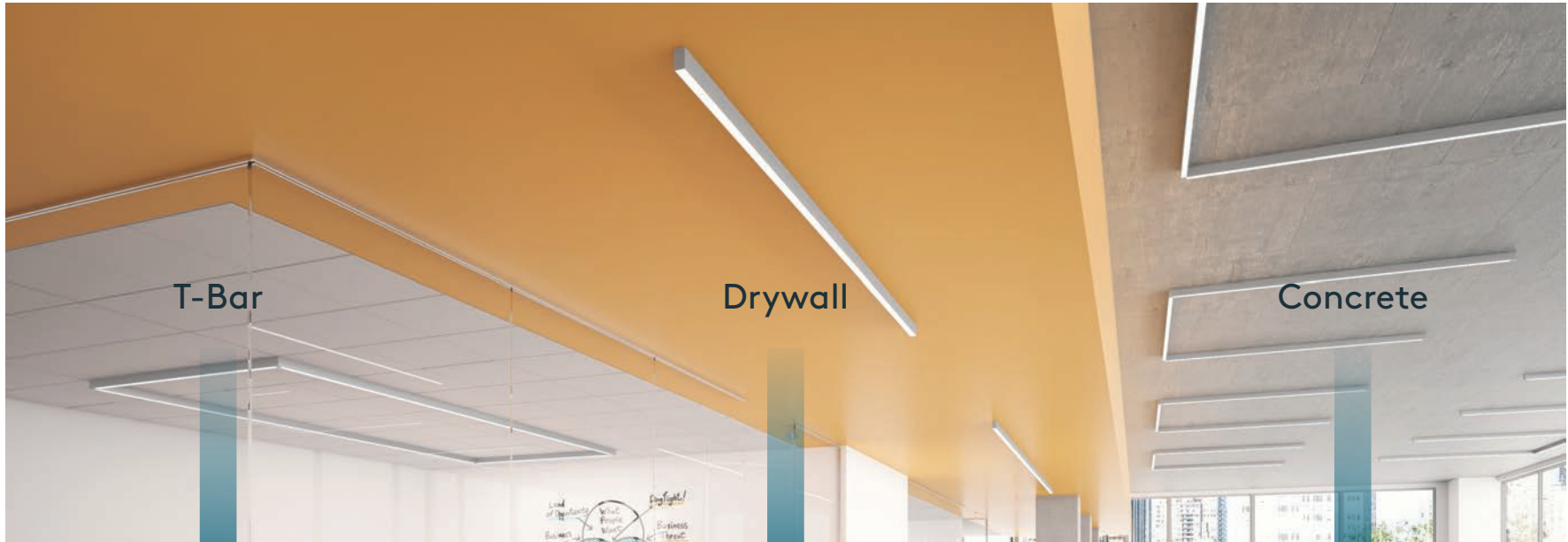

T-Bar

Drywall

Concrete

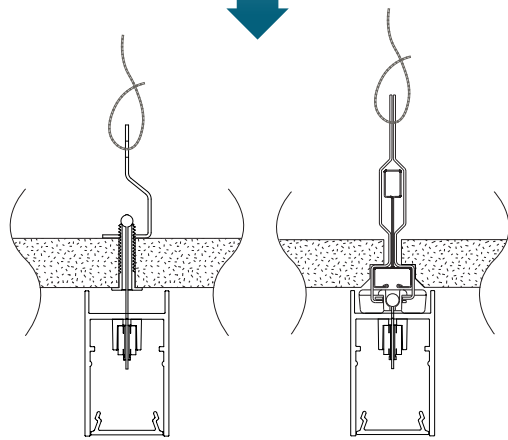

Off-grid

On-grid

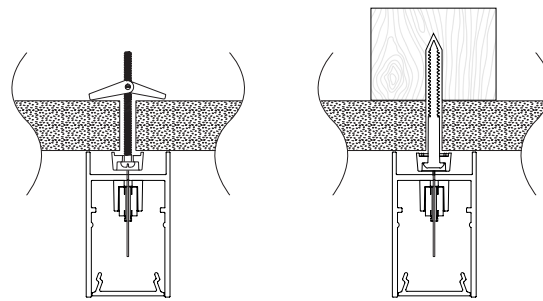

Through drywall

Through stud

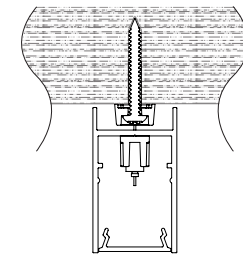

Innovative Mounting

Simple four-step installation

1 HANG

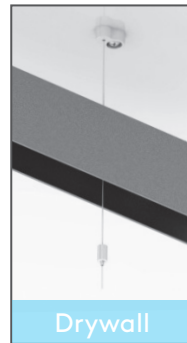
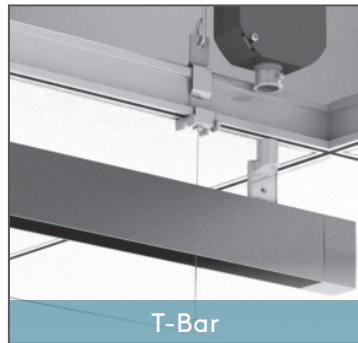

Suspend luminaire housing securely using patent-pending surface hardware.

(Axis-supplied hardware elements vary according to ceiling type. Concrete mounting available.)

2 CINCH

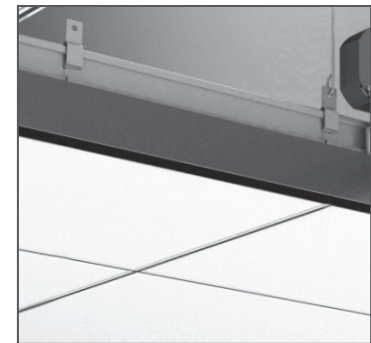
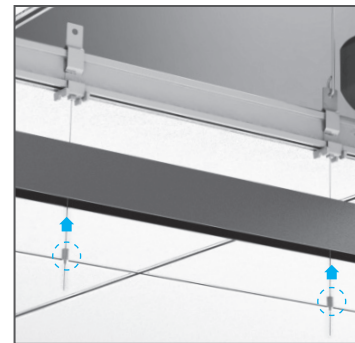

Cinch fixture up to the ceiling using patent-pending dual-cable system.

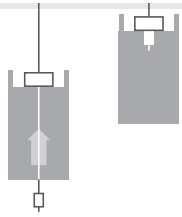

More affordability through innovation

Stencil Surface features patent-pending elements specially engineered to speed up the mounting process and significantly cut installation costs.

3 POWER

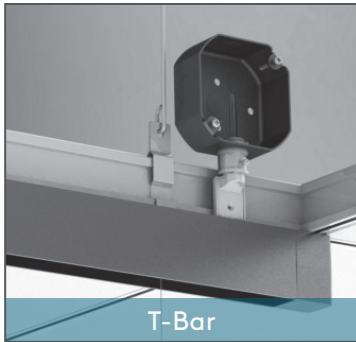

T-Bar

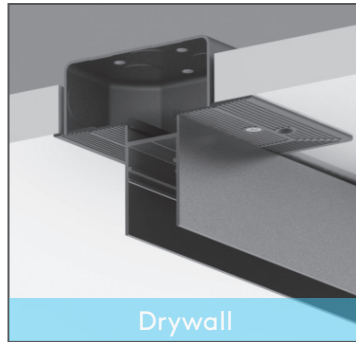

Drywall

Connect control and power feed using patent-pending invisible grid (9/16" T-bar or smaller) or drywall spackle feed. Concrete end feed and junction box cover available.



Optional miniature power feed box for 15/16" T-bar.

4 WIRE & SNAP IN PLACE

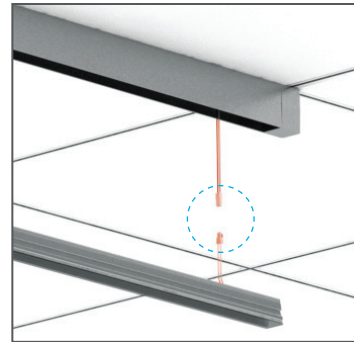

Housing compartment provides full access to drivers allowing for easy wiring of LED cartridge.

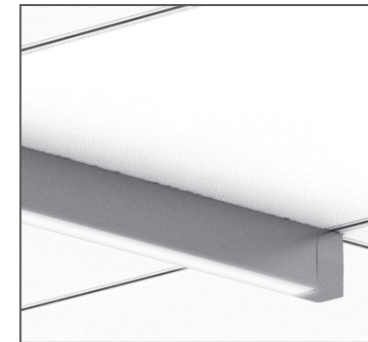

Full-length cartridge is snapped into housing in one quick step.

Hubs

The key to Stencil Surface design flexibility

- ✓ Patented die-cast soft-corners embrace the grid with style
- ✓ Non-illuminated connectors integrate seamlessly with the ceiling
- ✓ Ideal for branching off to bring light where you need it
- ✓ Easy to install with single captive spring-loaded screw mechanism



Y Hub
(120°)
AY



X Hub
(90°)
AX



L Hub
(90°)
AL



Inline Hub
(180°)
AI



Hub
end cap



Hex Hub
(120°)
AH



T Hub
(90°)
AT



Lifestyle
Sleeping + Sports + Exercise + Weight
HEALTHY
Balance + Nutrition + Eating + Diet



Aluminum Finish
Flush Lens

Segments

Flush and regressed options

- ✓ Combine with Hubs to build unique surface lighting forms
- ✓ Up to 500 lm/ft
- ✓ Efficacy of up to 108 lm/W
- ✓ Available in segment lengths of 2' to 8' in one-foot increments
- ✓ Up to 200' of continuous LED light from a single power drop
- ✓ Selection of lens and louver optical elements ensure visual comfort with low surface brightness
- ✓ Wood finishes available, please consult your Axis representative

Blank Segments

Choice of powered and non-powered versions. Use blank segments to create a power bridge or for esthetic continuity. Available in any length increment.

Flush segments

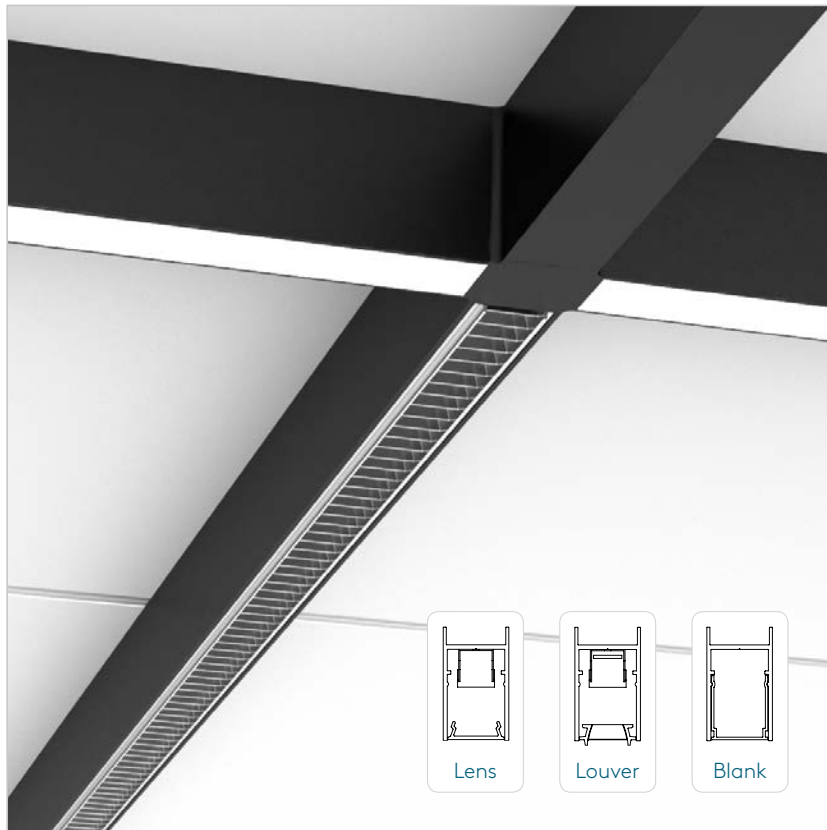

Regressed segments

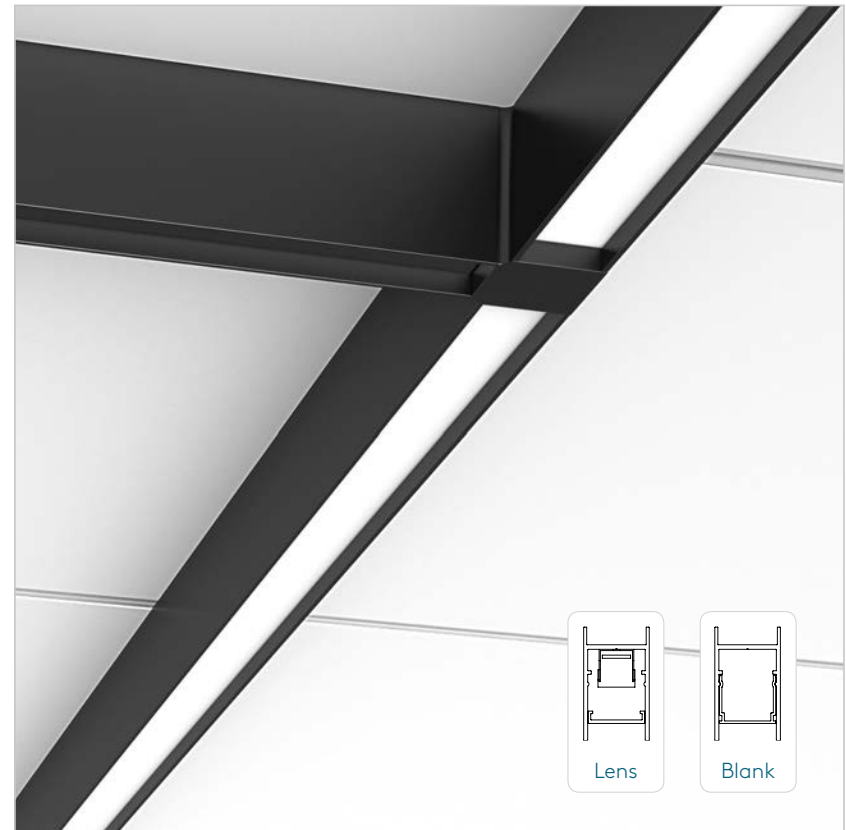



Accents

Layers of light provide added visual interest

Position Stencil Surface accent modules anywhere along the channel, individually or in clusters, using flush or regressed segments... You have all the lighting design freedom you need.

- ✓ 500 lm nominal (4253 cd @ 20°)
- ✓ 3000K, 80 CRI
- ✓ 359° rotation, 90° tilt
- ✓ 20° or 36° beam spreads
- ✓ Fully dimmable to 5% (integral 0-10V mini-driver)

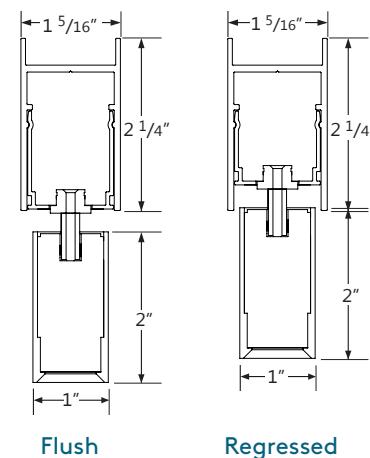



Wood Finish
Flush Lens & Accents

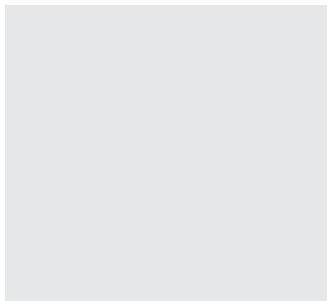

Embrace the grid

Imagine all you can do with Stencil Surface.
Get inspired and get creative.

Consult spec sheets at
axislighting.com/stencilsurface



Aluminum Finish
Flush Lens

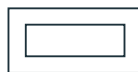
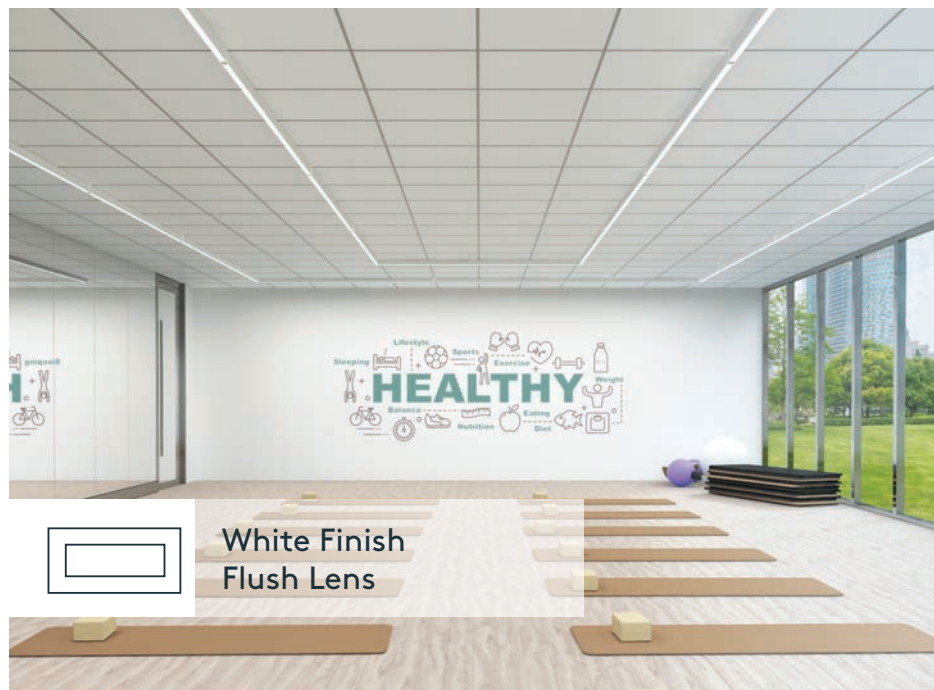

White Finish
Flush Lens

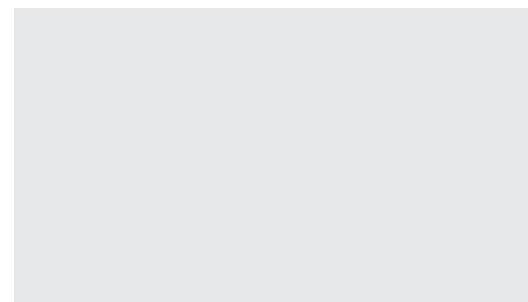



Black Finish
Flush Lens



Aluminum Finish
Flush Lens



Aluminum Finish
on T-grid, Drywall & Concrete



Black Finish
Flush Lens



White Finish
Flush Lens

About Axis Lighting

Founded in 1991 and still family owned and managed, Axis is an important source for architectural lighting across North America and around the globe.

Over the last decade, the company has exhibited remarkable growth thanks to its commitment to Design Flexibility, Optimal Energy Efficiency and Responsive Customer Care. That leadership effort now extends to developing Innovative Lighting Technologies, such as SurroundLite™, on an ongoing basis.

On the strength of a broad and expanding product line, Axis has successfully completed lighting projects for high-profile clients including Apple, Chrysler, The Empire State Building, Google, Hyundai, Time Warner and McGill University, among many others.

Axis has the drive and the expertise to meet your needs and provide architectural lighting... your way.



We reserve the right to change specifications without notice.
Please consult our website for the most current technical information
and to locate your nearest Axis representative.

1.800.263.AXIS

T 514.948.6272

F 514.948.6271

axislighting.com

© 2018 Axis Lighting Inc.